WEAVING TECHNOLOGY II

Chapter2:

History of Weaving

Classification of Weaving Machinery

HISTORY OF WEAVING (EVOLUTION OF WEAVING)

⌘ Horizontal loom

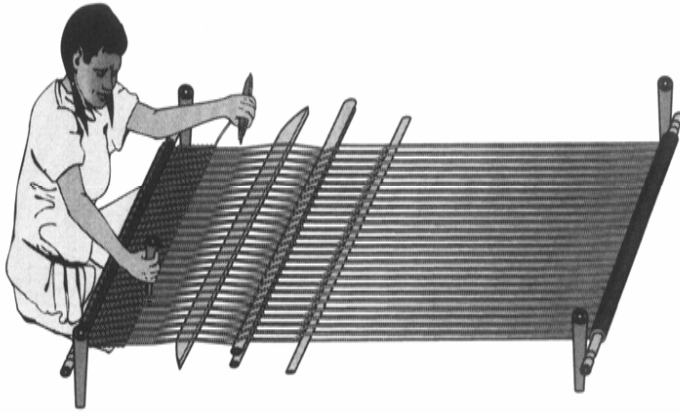

⌘ Backstrap loom

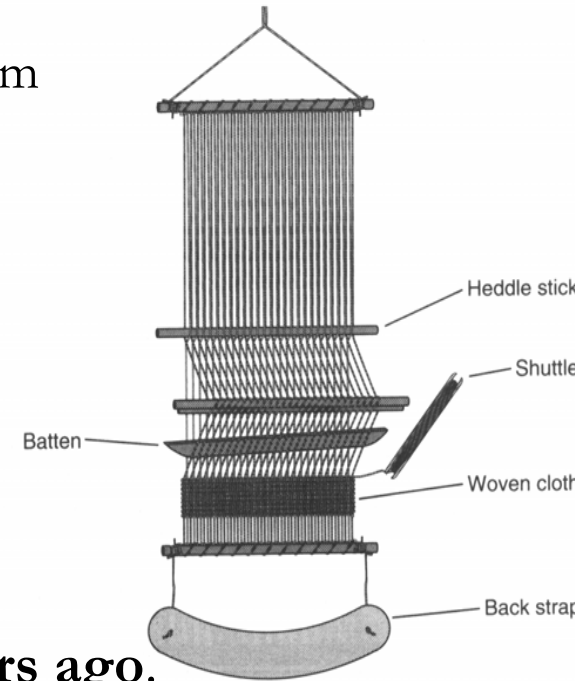

- **Egyptians** made woven fabrics some **6000 years ago**.
- Chinese made fine fabrics from silk over **4000 years ago**.
- A shedding mechanism was originally invented in China in the **3rd century** and introduced in Europe.

HISTORY OF WEAVING

- In **12th century**, completely wooden hand looms were used as standard designs in England.
- The developments in the design and performance of looms have taken place during the **past 850 years**.

Hand Looms

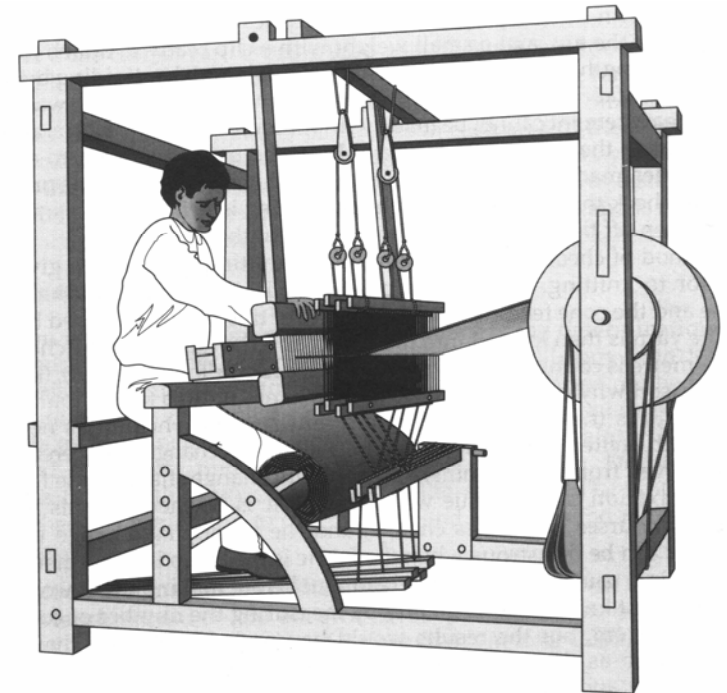

HISTORY OF WEAVING

- **The fly shuttle**, invented in **1733** by John Kay, was hand operated.
- It was an important cornerstone to improve the productivity.
- This shuttle, running on four wheels, was moving over the lower side of the warp sheet.
- Two wooden tenders connected to a small cord commanded by the hand were used to propel the shuttle. The weaver sitting in the middle of the loom threw the shuttle by pulling the cord very easily.

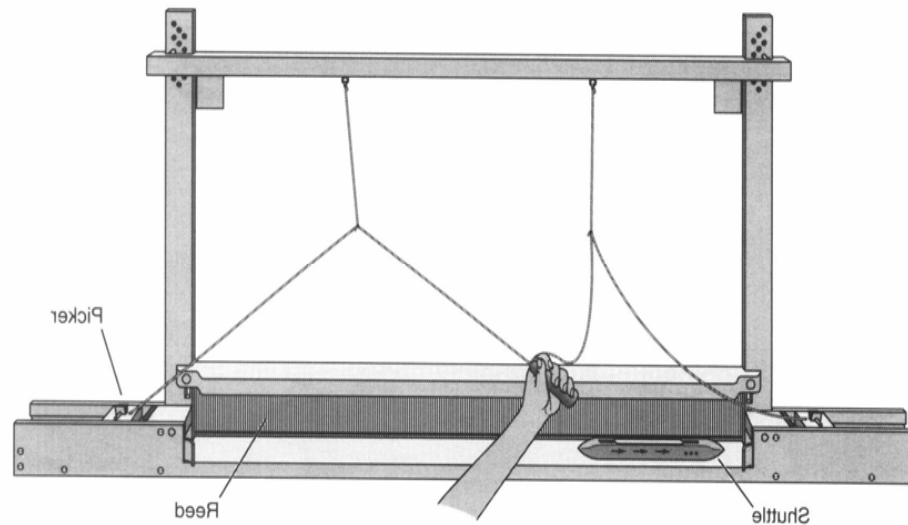

HISTORY OF WEAVING

Power Looms

- E.Cartwright invented **the power loom** in **1785**.
- In **the early 1800s**, looms made of cast iron were operated by **steam power**.
- In the 1830s, there were some 100,000 shuttle looms operating in England.
- In **1895**, many looms, all driven by an **electric engine** were invented and then became spread.
- At the beginning of **1930's**, eventually, each weaving machine driven individually by **an electric motor** was developed, this loom drive concept has remained in use until the present.

HISTORY OF WEAVING

Automation

- **The automatic loom stopping system** was invented by R. Miller in England in **1796**. The loom was automatically stopped when a short pick occurred.
- In **1894 Northrop** devised a means for automatic weft replenishment without stopping the loom which was called **automatic loom**.

HISTORY OF WEAVING

Shedding Mechanisms

- The **first dobbie** operated by a punched card was invented by **B. Bouchone in 1725**.
- A machine controlling bundles of harness cords with healds was constructed by **J.M. Jacquard in 1801**.
- The first **shuttle change motion** enabling weft threads of different colors to be inserted was constructed by **J.P. Reid and T. Johnson in 1835**.
- One significant invention in the field of design was that of **Keighley dobbie** by **Hattersley and Smith in 1867**.
- Rotary dobbies are manufactured in 1990s.

HISTORY OF WEAVING

Weft Insertion Systems

- **Projectile w.m.** was invented in **1924** by an engineer named Rossmann became commercial in **1953**.
- The first patent for the **rapier w.m.** was granted in **1898**, then followed the Gabler system in **1925** and the Dewas system in **1930**. Production of **rapier w. m.** started in **1972**.
- The first **air-jet system** was invented in **1914** but it became important commercially after **1980's**.
- **Continuous weft insertion** on a **circular w.m.** was proposed before the end of the 19th century.
- After mid 90s, **multi phase w.m.** has showed new developments. .

TEXTILE MACHINERY SHOWS

- Major developments have been revealed at the **three textile machinery shows** in the world:
 - **ITMA**, held every four years in Europe,
 - **ATME-I**, held every four years in US and
 - **OTEMAS**, held in Japan.
 - Textile machinery shows are also held every year in İstanbul by some national organizations

CLASSIFICATION OF WEAVING MACHINES

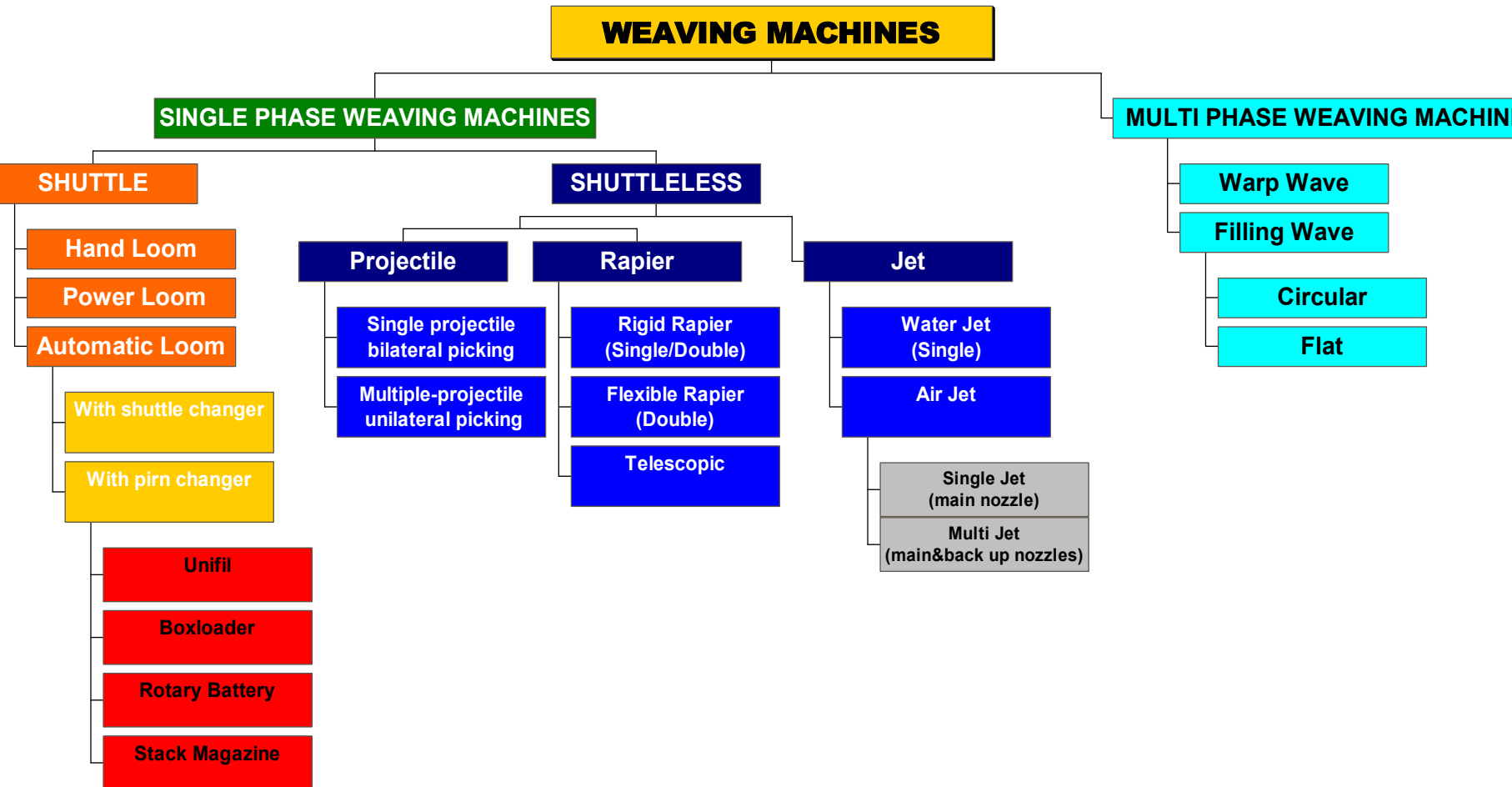

CLASSIFICATION OF WEAVING MACHINES

■ Single-phase weaving machines:

- There is a sequence in **primary motions of weaving**, and **each of them is repeated once in each weaving cycle**.
- The **weft insertion**, which is the principal weaving operation, takes place only at discrete intervals.

■ Multi-phase weaving machines:

- Several sheds are opened **simultaneously** and weft is inserted in them by several carriers.
- Several phases of the weaving cycle take place at any instant so that several picks are being inserted simultaneously.

Single Phase Weft Insertion Systems

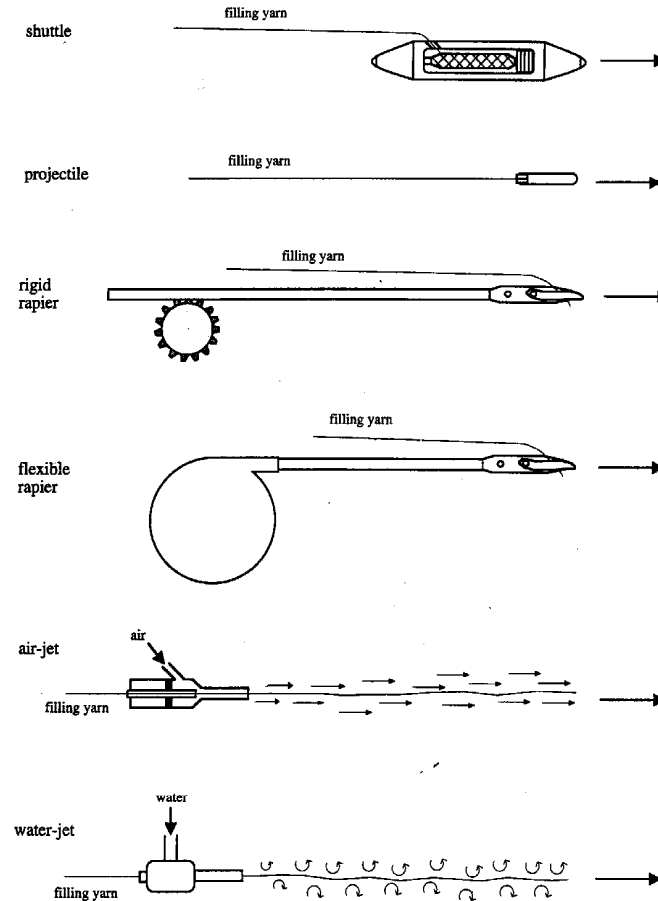

Principles of filling insertion systems.

Handbook of Weaving
Sabit Adanur

CLASSIFICATION OF WEAVING MACHINES

- **Shuttle Looms** (first generation)
 - **Hand Loom**-Every operation is performed manually.
 - **Power Loom** (non-automatic)- The shuttle is changed by hand.
 - **Automatic Weaving Machines**- A power driven loom on which the shuttles or pirns are changed automatically.

CLASSIFICATION OF WEAVING MACHINES

Shuttleless Weaving Machines (second generation)

- **PROJECTILE WEAVING**
- **A gripper projectile** transports a single weft yarn into a shed.
- **Projectile machines** are available with
 - **unilateral picking** combined with **multiple projectiles**, or
 - **bilateral picking** with a **single projectile**
- Multiple projectile weaving is suitable to weave dobby, jacquard, and terry fabrics, from continuous-filament as well as spun yarns, and with up to six different colors of weft.

PROJECTILE WEAVING

- The multiple - gripper w.m. is a versatile unconventional loom and it offers an advantage of a combination of a wide width and high speed in order to attain high productivity levels.
- Energy required for picking is built up by twisting a **torsion rod**.
- The projectile is braked in the receiving unit and conveyed to its original position by a transport device installed under the shed.

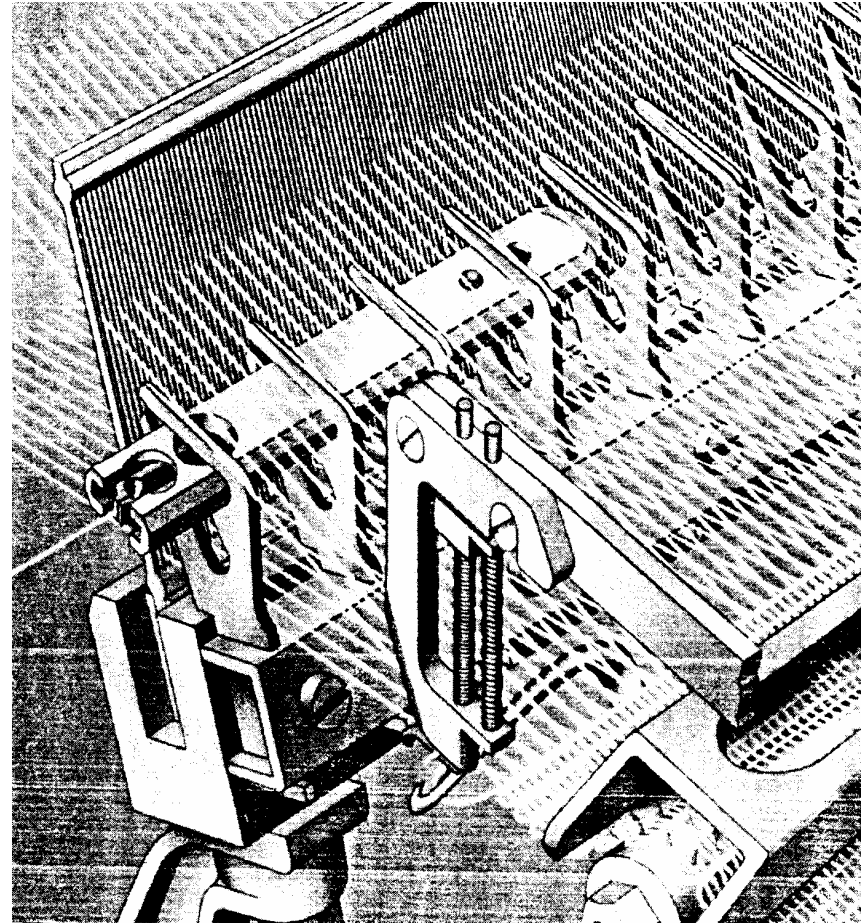

CLASSIFICATION OF WEAVING MACHINES

■ RAPIER WEAVING MACHINES

- The **single rapier w.m.**, extends the full width of the warp.
- In the weft insertion by **double rapiers**, the weft yarn is inserted half way into the shed by one carrier and then taken over in the center by the other carrier and drawn out to the opposite side of the fabric.
- The **telescopic rapier** is a kind of rigid rapier which enables a considerable floor space saving.
- It should also be remembered that only 50% of the rapier movement is utilized in weft insertion, and, for single-rapier looms, this wasted movement is also a time loss.
- The future of this method of weft insertion would appear to lie mainly in the field of multi-color work.



PS-Type

CLASSIFICATION OF WEAVING MACHINES

■ JET WEAVING MACHINES

- In a jet loom the weft thread is propelled across the loom by a jet of compressed air or by water. In this case, the mass of the weft carrier, known as air-jet or water-jet, is reduced to a minimum, say 1.5 g .
- **Water jet** looms have been shown to be most economical for producing certain types of plain continuous-filament fabric, especially when they are produced from hydrophobic synthetic-fiber yarns.
- **A jet of air** can be used to blow the weft yarn into the shed. This small mass of insertion fluid enables the mechanism to operate at extremely high insertion rates.
- **Air jets** are either **single jet** machines or utilize **'back-up'** jets.
- Air jet looms are more popular for the weaving of some cotton-type fabrics, as well as for continuous-filament yarns.



CLASSIFICATION OF WEAVING MACHINES

Multi Phase Weaving

- Further increases in production rates of woven fabrics require new technologies such as multi phase weaving.
- In the **filling direction shed wave principle**, a number of sheds in weft direction are opened subsequently for the insertion of the weft.
- Sheds are arranged wave-like from one side to another so that weft carrier slides into each shed.
- The machine may be rectangular (flat) or circular.

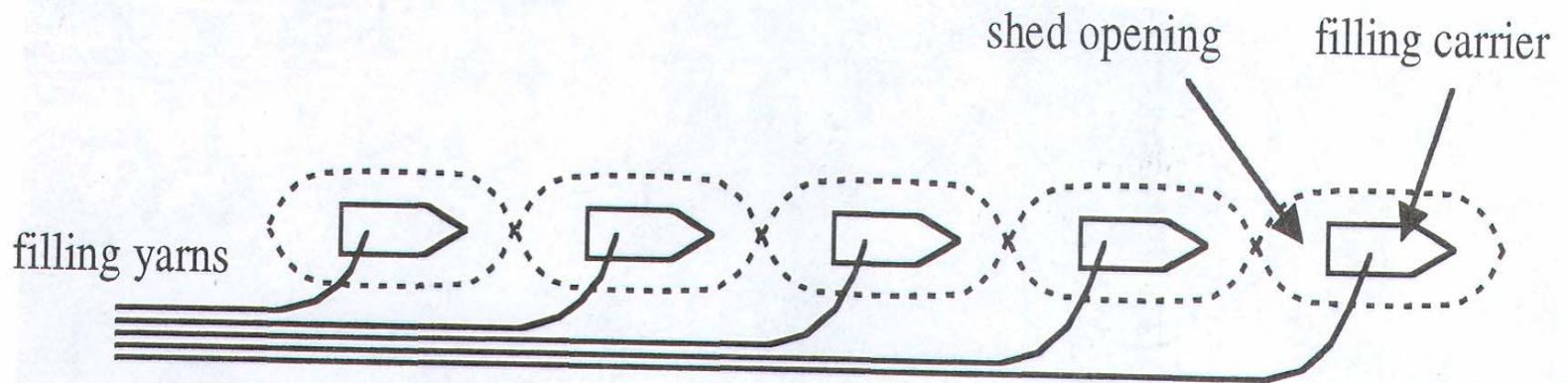

CLASSIFICATION OF WEAVING MACHINES

Multi Phase Weaving

- As the weft carrier enters one portion of the warp, the shed is formed; as the carrier leaves that area, the shed changes.
- The action may occur simultaneously across the width of the warp several times.
- As a result, at any moment, there are several shuttles in the shed, each carrying a different yarn.
- Disadvantages:
 - Missing picks cannot be easily repaired.
 - Warp and weft threads are not perfectly perpendicular to each other.

Wave shed principle

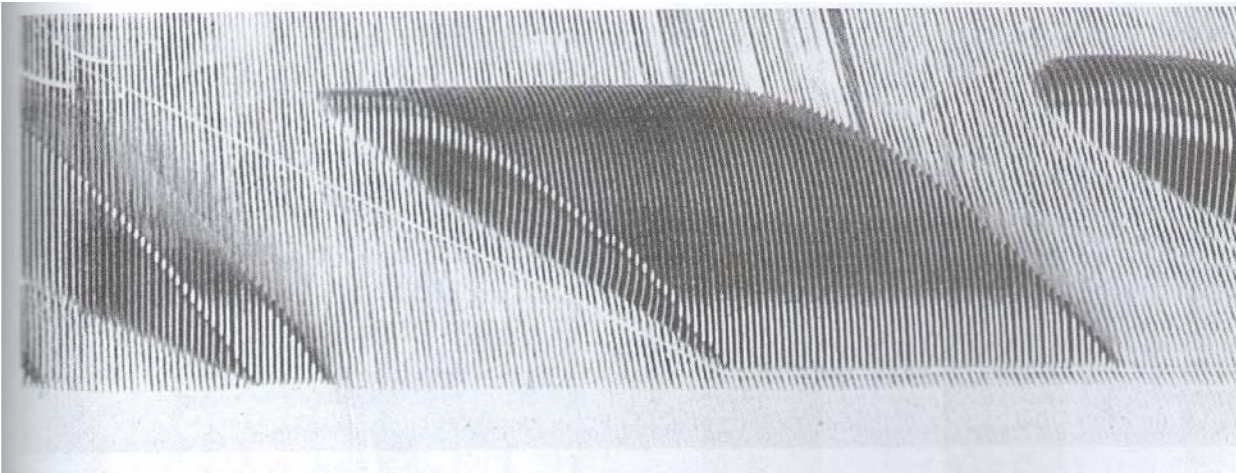
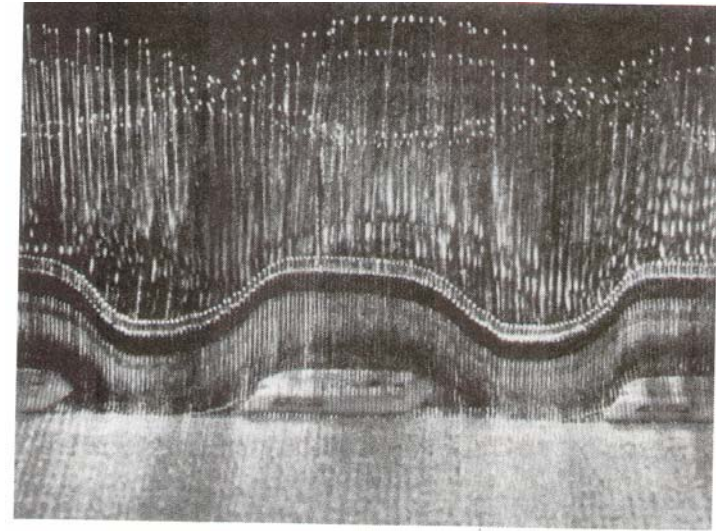
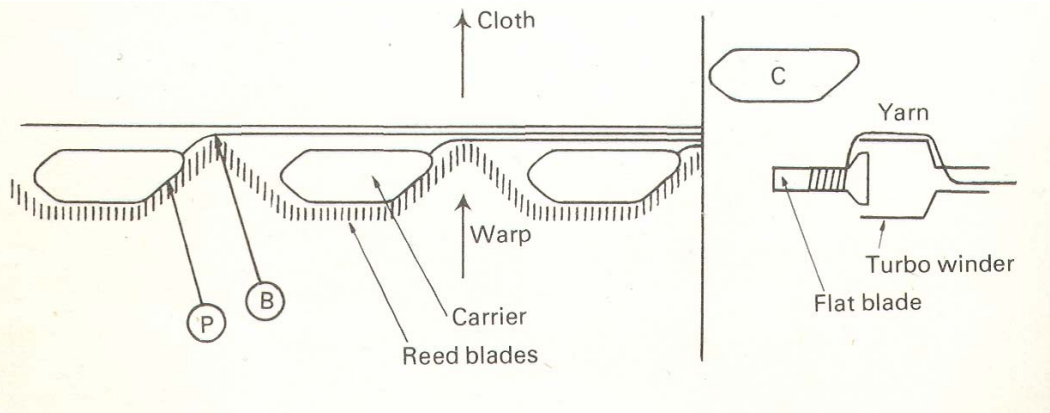

Rotating reed

CLASSIFICATION OF WEAVING MACHINES

Multi Phase Weaving

- Although they have been used for quite some time, circular w.m. they are not frequent textile industry.
- The main reason is the lack of flexibility in the fabric width and narrow range of options. Only sack and tubes are woven on circular w.m. Usually only plain and twill weaves are possible.
- In a **circular w.m.**, the warp is circular, and there are continuously circulating shuttles running around the periphery in a wave or ripple shed..
- Shuttles cannot leave the shed and have a continuous motion.
- Shuttles are driven electromagnetically and each shuttle runs in its own shed.
- Warp is divided into two segments and forms the shed with small heddle frames or wires.
- The beat up is performed by needle gears.

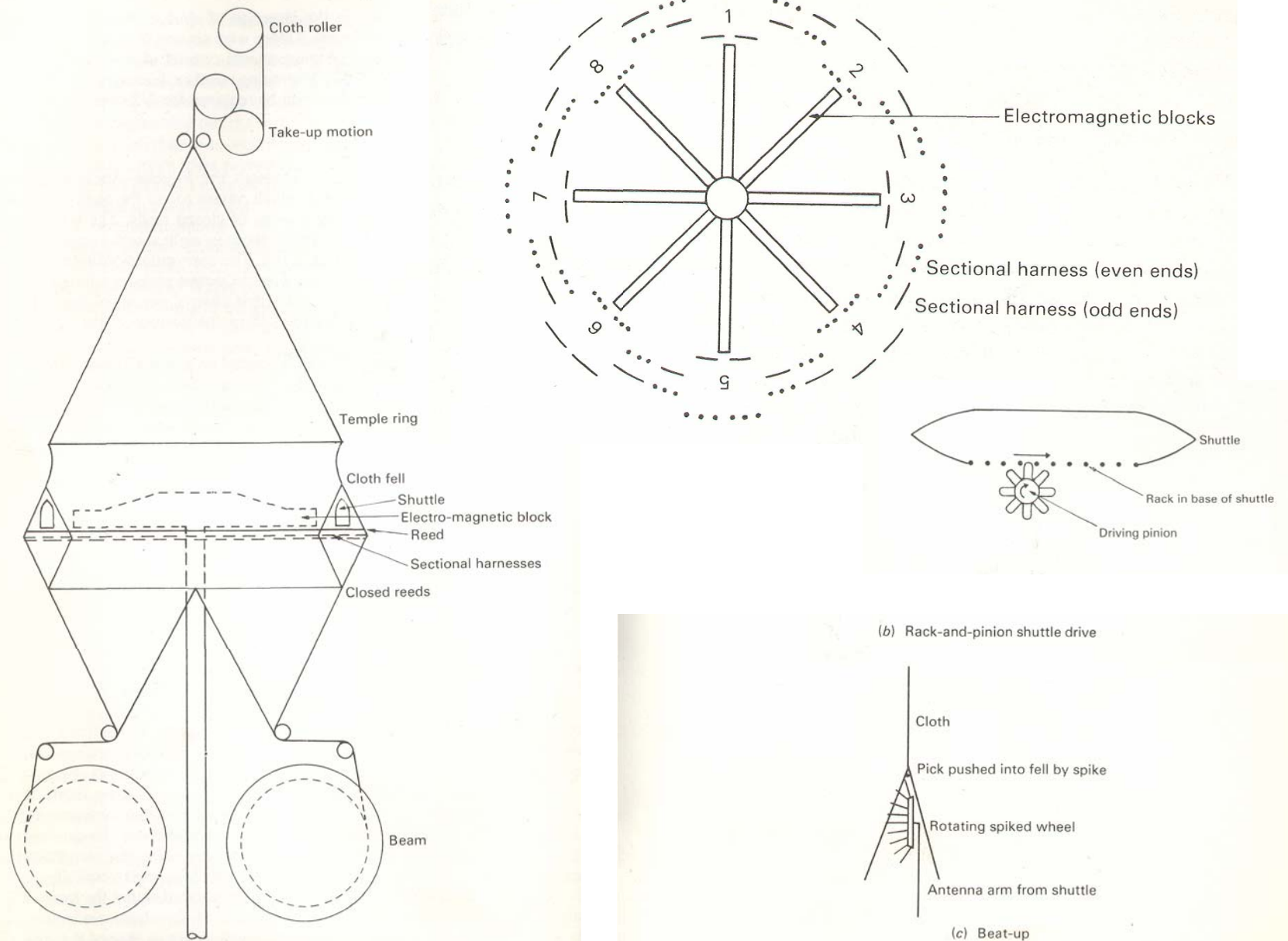
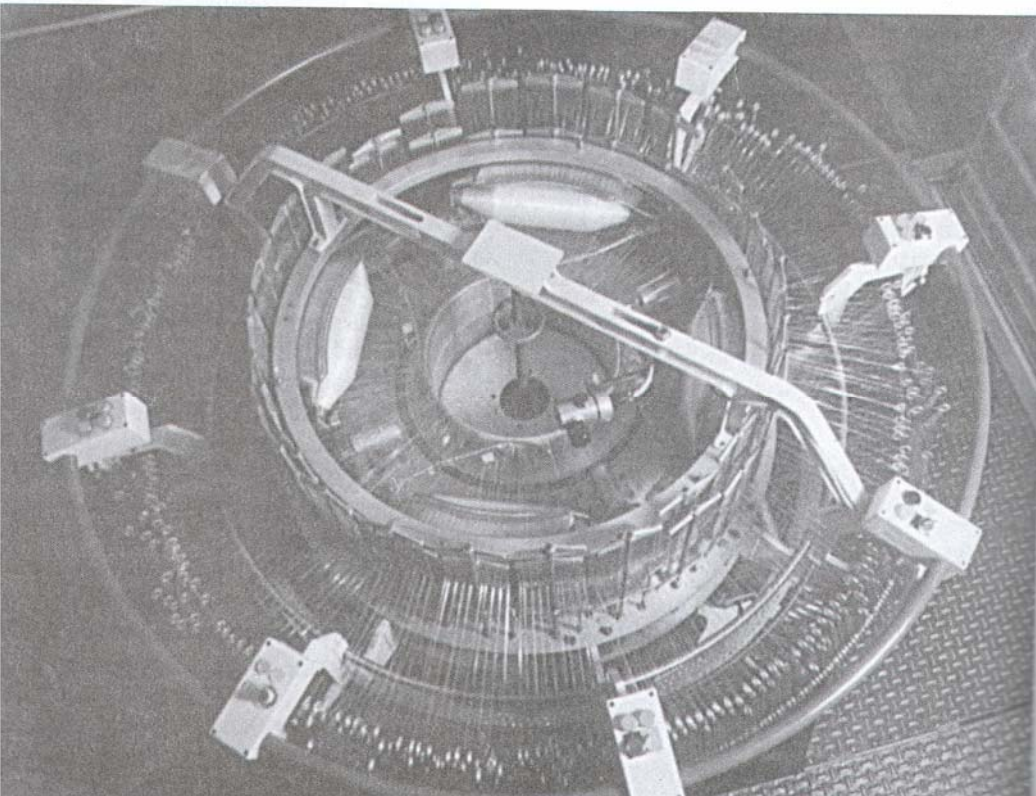
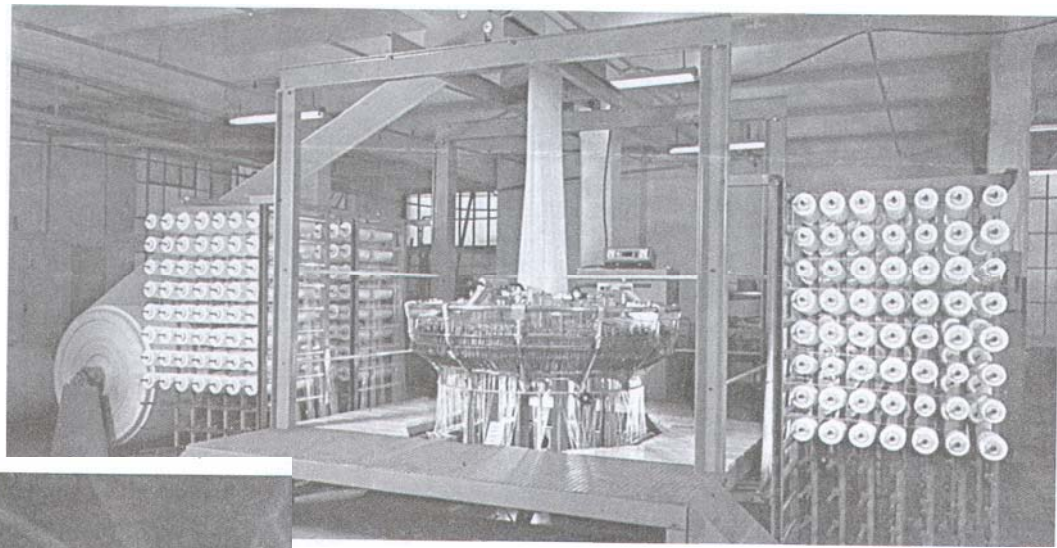

Fig. 5.18 The passage of the warp through a circular loom (Fayolle-Ancet)



CLASSIFICATION OF WEAVING MACHINES

Multi Phase Weaving

- In the **warp direction shed wave principle**, a number of sheds are opened in the warp direction at the same time for the weft insertion.
- These sheds are opened one after another in the warp direction; however there are several sheds that are open at any given time.
- Each shed extends across the full width of the warp and moves in the warp direction. The weft yarn can be inserted in a manner similar to that of conventional weaving systems.
- This concept is called **sequential-shed principle** or **multi-linear shed principle** (M8300)
- Compared to single-phase weaving machines, three - to fourfold productivity with simple standard fabrics

CLASSIFICATION OF WEAVING MACHINES

Multi Phase Weaving

- The warp ends pass over the rotating weaving rotor; the sheds are formed consecutively on its circumference by shed forming elements.
- Motion of the rotor causes the shed forming elements to open the sheds one after another.
- The weft yarn is inserted by low pressure compressed air through the channel across the full width of the fabric
- Four pick can be inserted simultaneously.
- The yarn velocity is 20 m/s at an insertion rate of 5000 m/min.
- Beat up combs are located on the weaving rotor between the rows of shed forming elements perform the function of the conventional reed

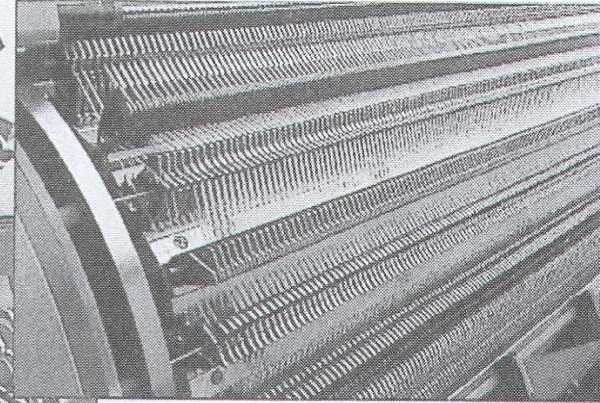
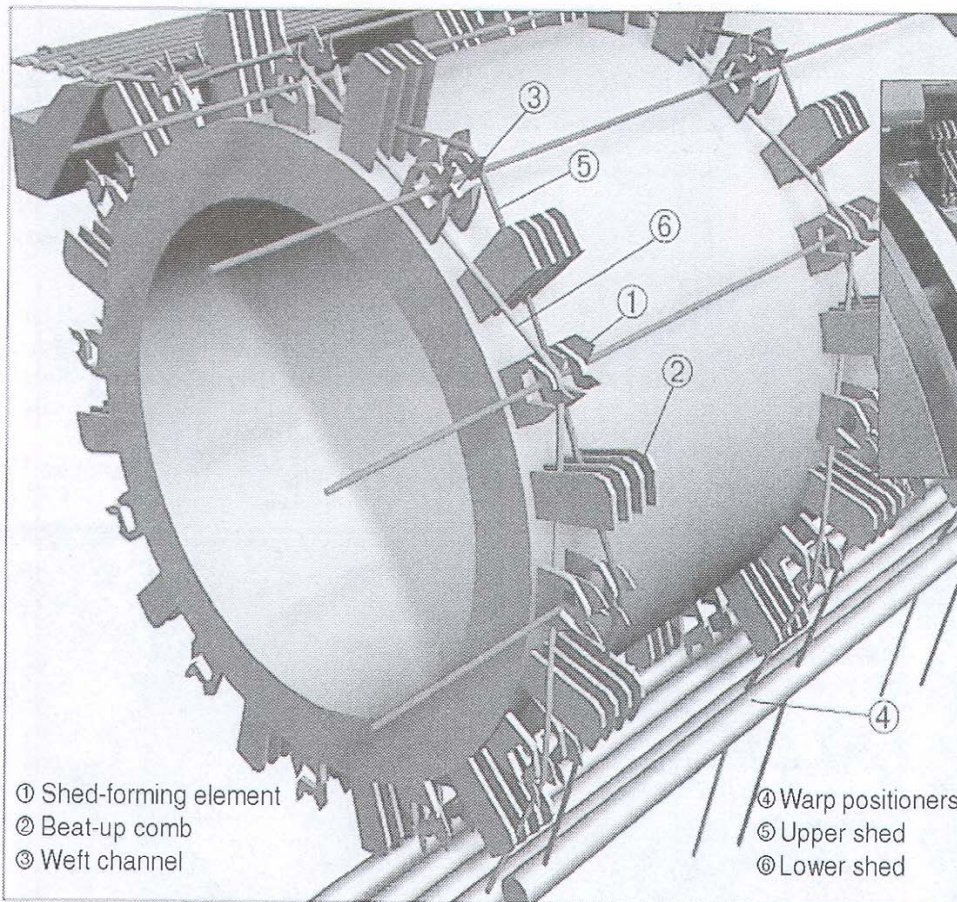

- ① Shed-forming element
- ② Beat-up comb
- ③ Weft channel

- ④ Warp positioners
- ⑤ Upper shed
- ⑥ Lower shed

Shed forming elements

Warp yarn positioning

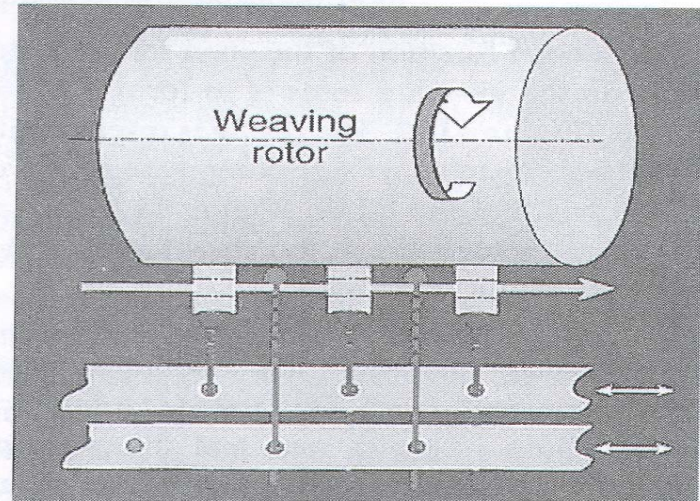

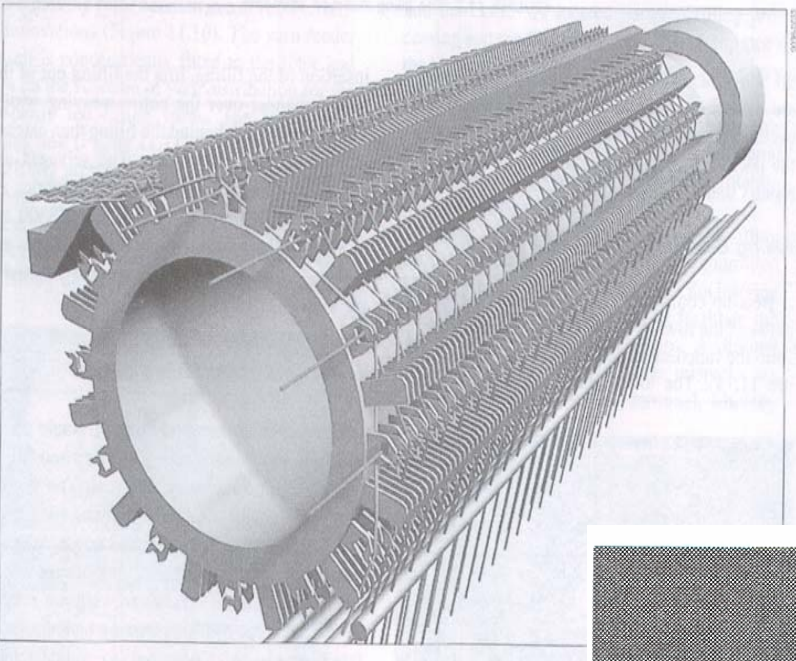

Shed geometry

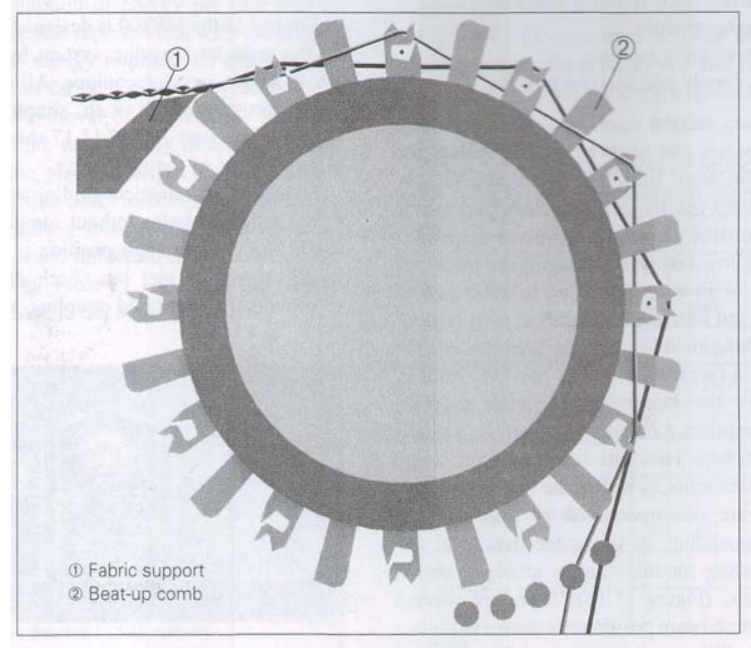

Beat up combs

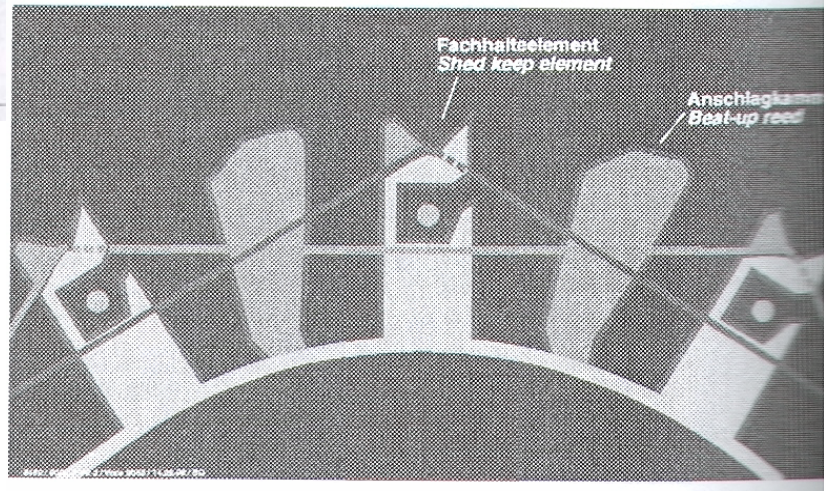

Weft insertion rate: 5000 m/min

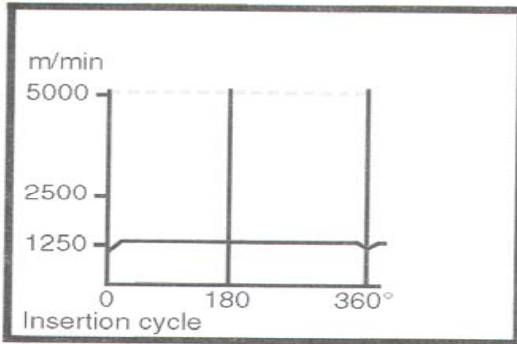

Weft insertion rate: 2000

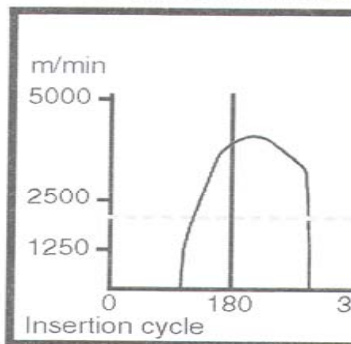

--- Weft insertion rate of machine
— Speed of individual weft

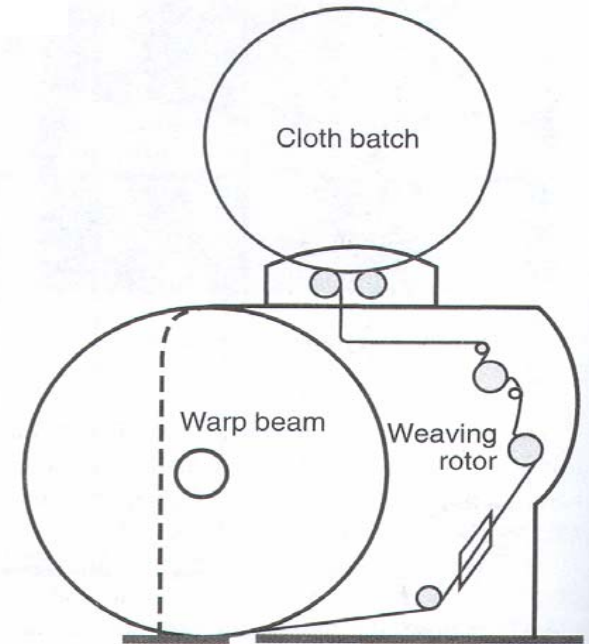

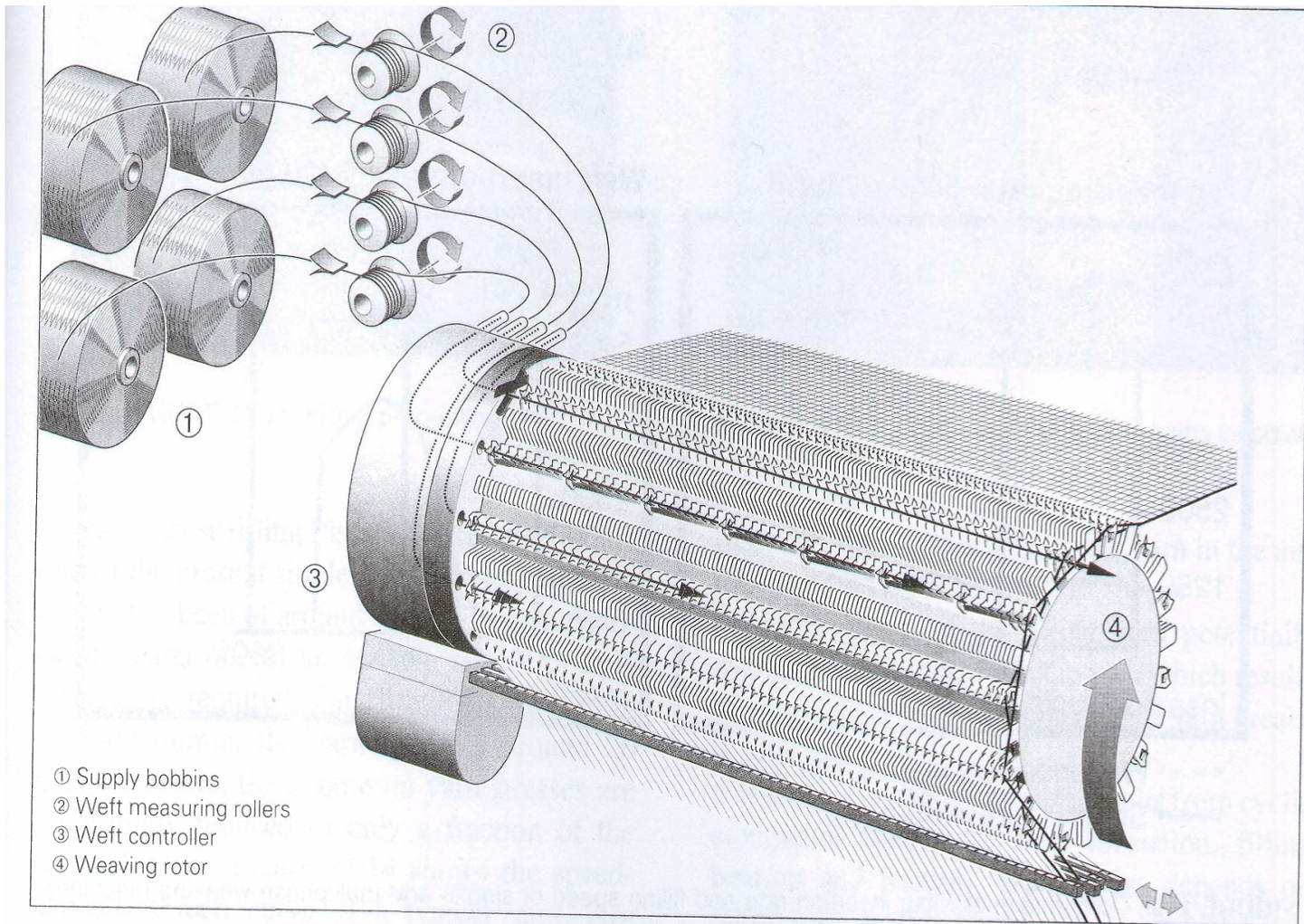

CLASSIFICATION OF WEAVING MACHINES

■ Light-weight Weaving Machines

- Normal Constructions
 - Cotton weaving m.
 - Silk weaving m
- Constructions with special mechanisms
 - Terry-towel weaving m
 - Broché weaving m.

■ Heavy-weight Weaving Machines

- Normal constructions
 - Wool weaving m.
 - Blanket weaving m
 - Sailcloth weaving m
 - tapestry&upholstery w.m.
 - Industrial fabric w.m
- Constructions with special mechanisms
 - Carpet weaving m.
 - Velvet weaving m.